

1-PC SCREWED END BALL VALVE 1000 WOG

FEATURES :

- REDUCED BORE
- LOCKING-DEVICE (OPTIONAL)
- ANTI BLOW-OUT STEM
- WORKING PRESSURE 1000 WOG / PN63
- MATERIAL CONFORM TO ASTM A351 GR. CF8 & CF8M
- END CONNECTIONS : FEMALE THREADED ENDS ISO 228/1
- MADE BY LOST WAX INVESTMENT CASTING
- STANDARD PRACTICE : MSS-SP-110-1996
- TESTED ACCORDING TO : API 598 & MSS SP-61-2009

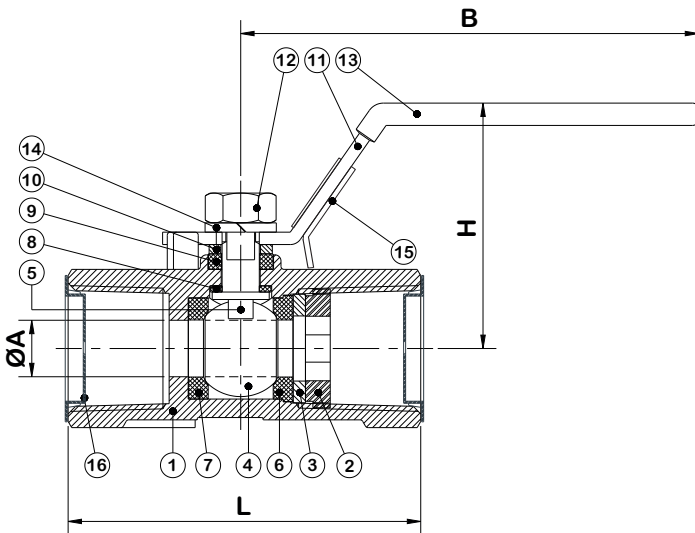
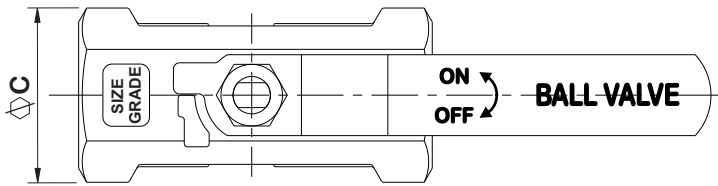

PRESSURE-TEMPERATURE RATING

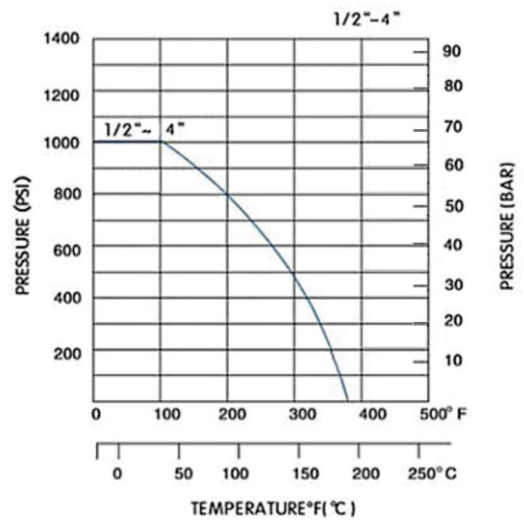

DIMENSIONS

No.	Size	ØA (mm)	B (mm)	ØC (mm)	L (mm)	H (mm)	Weight (Kg/Pcs)
1.	1/2"	9.1	73.0	25.5	56.9	39.2	0.15
2.	3/4"	12.5	87.5	30.1	56.0	47.4	0.21
3.	1"	15.0	87.5	36.9	65.8	50.7	0.30
4.	1 1/4"	20.0	106.0	45.7	71.8	52.1	0.52
5.	1 1/2"	25.0	106.0	51.7	78.2	55.8	0.66
6.	2"	31.8	127.0	63.0	95.0	68.7	1.03
7.	2 1/2"	38.6	147.5	80.0	111.0	85.7	1.85
8.	3"	48.0	147.5	93.0	135.0	97.5	3.00
9.	4"	65.5	240.0	119.7	167.3	129.7	6.00

No.	PART NAME	MATERIAL
1.	Body	ASTM A351-CF8M
2.	Cap	ASTM A351-CF8M
3.	Plate Ring	ASTM A276-316
4.	Ball	ASTM A276-316
5.	Stem	ASTM A276-316
6.	Seat	PTFE
7.	Seal	PTFE
8.	Thrust Washer	PTFE
9.	Packing	PTFE
10.	Gland Packing	AISI 304
	Gland Nut*	AISI 304
11.	Handle	AISI 304
12.	Stem Nut	AISI 304
13.	Handle Sleeve	PLASTISOL / PVC
14.	Spring Washer	AISI 304
15.	Locking Device	AISI 304
16.	Plastic Cover	HDPE

* For sizes 2 1/2" to 4"